

# *Independence*

MADE *easy*



## The Acorn 80 Curved Stairlift

With the Acorn 80 Curved Stairlift, there's no longer any need to compromise your independence and struggle with the stairs in your home. Caring about your personal needs, Acorn truly can provide a solution that will make life easier for you. Whatever the reason, you can be proud to join the thousands of people all over the world who enjoy independent living at home, thanks to the Acorn 80.

With a built-in soft start and stop facility, the Acorn 80 gives you a smooth comfortable ride every time, and you can be sure that your stairlift is always ready for use thanks to the integral rechargeable battery pack, even in the event of a mains power failure.

The Acorn 80 fits practically any curved staircase, and its slim, attractive rail fits to your stairs, so there's no damage to your home. Together with a smooth, quiet operation, an Acorn Stairlift is an attractive addition to any home.

The Acorn 80 has been carefully designed to include a wide variety of comfort and safety features, to provide you with many years of safe and reliable enjoyment of your stairlift. To ensure your lift is simple and effortless to operate, the Acorn 80 has also been designed with ease of use and comfort in mind.

The unique self-levelling transport system moves the stairlift carriage along the low profile rail and automatically adjusts the speed and level of the seat when moving round corners, providing an exceptionally smooth ride. The stairlift's electronic programming ensures optimum performance at all times.

The footrest of the Acorn 80 is extremely close to the ground floor level, and has no step; also it ends level with the top stair nose, giving easy access to the landing.

When not in use, the Acorn 80 can be folded away; its slim profile and unique inside parking ability ensures that the staircase is not obstructed, allowing other members of the household to use the stairs as normal.



A WEALTH OF

# features

FOR YOUR BENEFIT

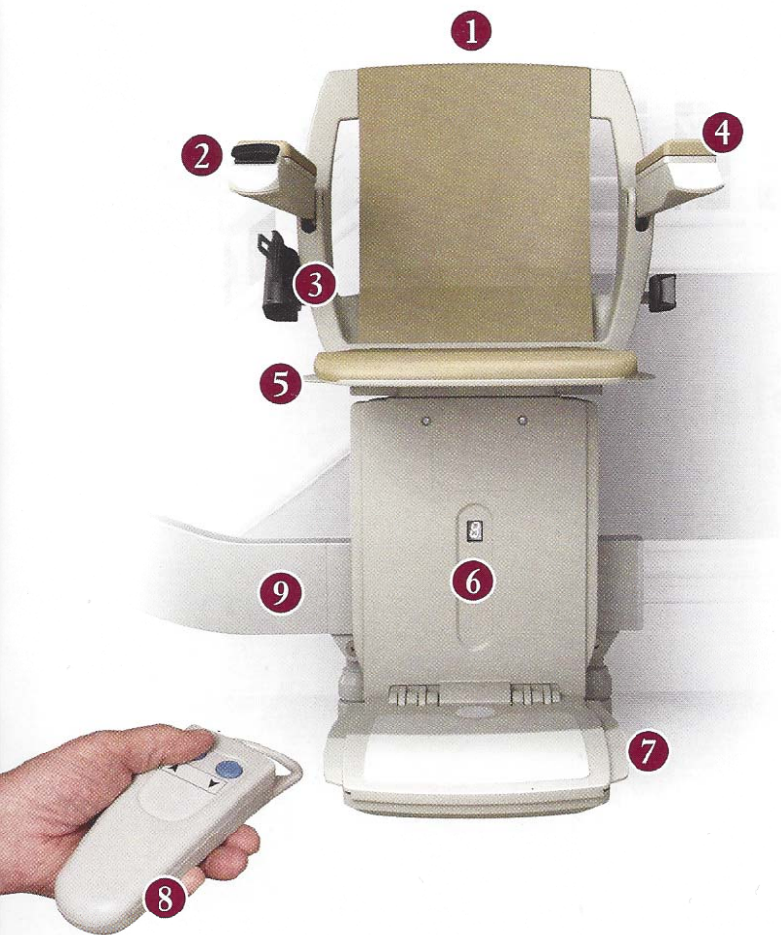

- 1 Padded seat and backrest.
- 2 Easy to use controls.
- 3 Secure safety belt.
- 4 Folding arms, footrest and seat allow easy access to the staircase.
- 5 Swivel seat - no need for twisting the body to get on and off the lift.
- 6 Diagnostic digital display informs the user of the status of the lift.
- 7 Safety sensors on the footrest and carriage stop the lift automatically if any obstruction is encountered.
- 8 Hand-held remote controls allow users to 'call' or 'send' the lift up and down the staircase.
- 9 Modular rail allows the rail portion of the lift to be quickly assembled from stock components, enabling faster delivery and an installation time to suit you.

## Dimensions

	<i>mm</i>	<i>inches</i>
<b>A</b> Floor to top of footrest	50	2
<b>B</b> Top of footrest to top of seat	490-580	19-23
<b>C</b> Top of seat to top of arms	247	9.7
<b>D</b> Top of arms to top of seat back	203	8
<b>E</b> Width between armrests	450	18
<b>F</b> Overall width	567	22
<b>G</b> Overall height	950-1030	37-41
<b>H</b> Length of arms from seat back	400	16
<b>I</b> Length of seat base from seat back	370	15
<b>J</b> Length of footrest	365	14
<b>K</b> Width of footrest	375	15
<b>L</b> Front of footrest to stringer	640	25
<b>M</b> Back of seat to stringer	90	3.5
<b>N</b> Folded width	320	13

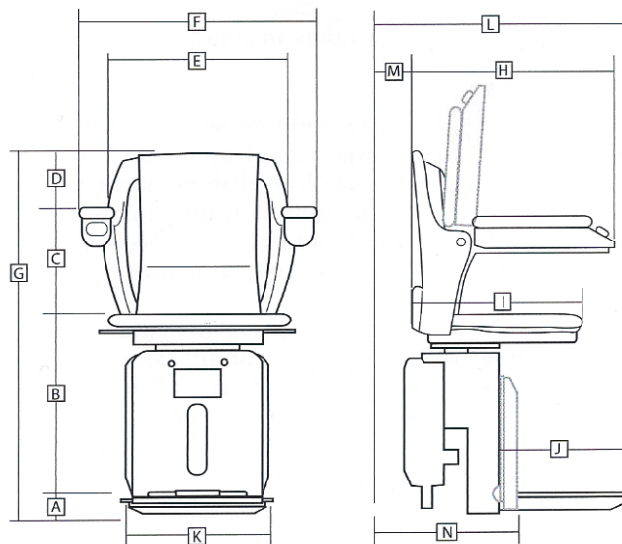

Dealer stamp:



Acorn, in keeping with its policy of continual development, reserves the right to change specifications without notice. All measurements are approximate. Images are shown for illustrative purposes only. Product may vary slightly.

GIVE YOUR LIFE A LIFT®